

User Guide NX-3DPDF

Product Category	CADPublish
Product Group	NX<>3DPDF
Product Release Version	28.0

Document Type	User Guide
Document Status	Released
Document Revision	1.0
Document Author	Bruce Pittman
Document Issued	01/04/2025

📍 THEOREM HOUSE
MARSTON PARK
BONEHILL RD
TAMWORTH
B78 3HU
UNITED KINGDOM

☎ +44(0)1827 305 350

📍 THEOREM SOLUTIONS INC.
100 WEST BIG BEAVER
TROY
MICHIGAN
48084
USA

☎ +(513) 576 1100

Contents

Overview of CADPublish.....	3
<i>About Theorem</i>	<i>3</i>
<i>Theorem’s Product Suite</i>	<i>4</i>
CADTranslate	4
CADPublish.....	4
TheoremXR	4
The NX 3DPDF Translator	5
<i>Primary Product Features</i>	<i>5</i>
<i>Primary Product benefits?.....</i>	<i>6</i>
Getting Started	7
<i>Documentation & Installation Media.....</i>	<i>7</i>
<i>Installation</i>	<i>7</i>
<i>License Configuration.....</i>	<i>7</i>
<i>Using the Product.....</i>	<i>7</i>
Using the Product.....	8
Publish 3D On-Demand	8
Default Publishing	9
Translator Customization	18
<i>Common Options for NX Publishing.....</i>	<i>18</i>
Command Line Advanced Arguments.....	26
<i>NX Advanced Arguments.....</i>	<i>26</i>
<i>3DPDF Advanced Arguments.....</i>	<i>28</i>
Publish 3D Interactive	35
Setting your own NX Custom Dirs file	37
Options for Processing FTA Data with Filled Text	37
<i>Configuration Manager</i>	<i>37</i>
Security Changes to Adobe Reader	39

Overview of CADPublish

About Theorem

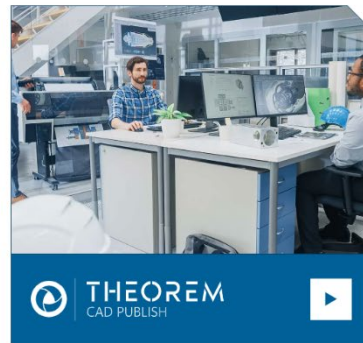

Theorem Solutions is a world leader in the field of Engineering Data Services and Solutions. This leadership position stems from the quality of our technology and the people in the company. Quality comes not only from the skills and commitment of our staff, but also from the vigorous industrial use of our technology & services by world leading customers.

We are proud that the vast majority of the world's leading Automotive, Aerospace, Defense, Power Generation and Transportation companies and their Supply chains use our products and services daily. Working closely with our customers, to both fully understand their requirements and feed their input into our development processes has significantly contributed to our technology and industry knowledge.

Theorem Solutions is an independent UK headquartered company incorporated in 1990, with sales and support offices in the UK and USA. Theorem has strong relationships with the major CAD and PLM vendors, including; Autodesk, Dassault Systemes, ICEM Technologies (a Dassault company), PTC, SolidWorks, Spatial Technology and Siemens PLM Software. These relationships enable us to deliver best in class services and solutions to engineering companies worldwide.

Theorem's Product Suite

Theorem have 3 main Product brands. These are:



CADTranslate

CAD Data Exchange: Seamless and robust data translation between CAD and Visualization formats.

See our [website](#) for more detail.



CADPublish

Interactive Documentation: 3D PDF Publisher and Composer. Making CAD data accessible to non-CAD users.

See our [website](#) for more detail.



TheoremXR

Visualization for [Augmented \(AR\)](#), [Mixed \(MR\)](#) and [Virtual \(VR\)](#) Reality applications

Extended Reality – XR: Augmented, Mixed and Virtual Reality for the Engineering Metaverse.

See our [website](#) for more detail.

The NX 3DPDF Translator

The NX-3DPDF to JT translator may be installed on a number of machines each accessing a central network-floating license.

It enables the user to convert all forms of 3D Mechanical Design Geometry and Assembly data, together with system defined attribute information, color information to 3dpdf. This product is designed for companies using NX who have selected 3dpdf to be their main method of collaboration and communication between OEMs and their customers or suppliers.

The translator can be invoked in either an interactive or batch mode with the command line interface allowing the conversion process to be integrated into any process oriented operation.

Primary Product Features

- Converts all types of geometry, wire frame, surfaces, trimmed surfaces (faces) and solid models.
- Converts assembly structure from NX to 3dpdf.
- Converts attribute data including colour and layer information.
- Integrated with the NX installation.
- The conversion process can be run Interactively, Batch Mode or using the Unified Interface
- Command line interface allows process integration.
- Data can be filtered by layer and entity type during processing. Geometry can be filtered and selectively processed.
- Uses the Siemens API to read data.

Primary Product benefits?

- Being a direct database converter all pre and post processing is eliminated, saving time.
- Reduce costs due to processing time and increase overall conversion success levels by filtering input data and focusing the conversion to only those elements required.
- Reduce costs and risks associated to accessing the wrong version of data by integrating the conversion process into a related business processes.
- With over 20 years of industrial use Theorem translation products robustness and quality is well proven, reducing your business risk.

This document will focus specifically on guidance for the use of the NX-3DPDF product. For information regarding any of Theorem's product ranges please contact sales@theorem.com

Getting Started

Documentation & Installation Media

The latest copy of the User Guide documentation can be found on our web site at:

<http://www.theorem.com/Documentation>

Each product has a specific link that provides user documentation in the form of PDF and Tutorials.

The latest copy of Theorem software can be found via the link above and by searching for the specific product. Each product has a specific link to the Product Release Document, which contains a link to the download location of the installation CD.

Alternatively, you can request a copy of the software to be shipped on a physical CD.

Installation

The installation is run from the .msi file download provided. For full details of the installation process, visit www.theorem.com/documentation and select UI from the product selection list.

License Configuration

To run any product a valid license file is required. The Flex License Manager is run from the .msi file download provided. For full details of the installation process, visit www.theorem.com/documentation

Using the Product

To use the product, follow the documented steps found in this document or follow the online video tutorials which can be found from www.theorem.com/documentation

Using the Product

Publish 3D On-Demand

By default the Publish 3D for NX translator will translate source data using a default template. This template can be used as a basis for a customer's specific template design and illustrates fundamental capabilities of the translator with regard to publishing 3D data into a pre-defined document format. More complex template examples are provided in the following the locations:

<installation_directory>\data\publish_3dpdf

- default_Manifest – Illustrates various Adobe capabilities
- publishBlank – Illustrates publishing to a blank template

<installation_directory>\data\publish_3dpdf\templates

- publishBOM – Illustrates how to output an Assembly Bill of Materials
- publishMotion – Illustrates using CAD data with motion in PDF
- publishViewer – Illustrates JavaScript additions to a template replicating a CAD viewer
- publishECR – Illustrates a simple Engineering Change Request
- publishRFQ – Illustrates a simple Request for Quotation
- publishAttachments – Illustrates adding attachments to a template

These templates are supplied as examples only and can be used by customers as a guide to creating their own template documents.

Theorem offer a wide range of services to assist customers with their document creation needs. If you would like more information regarding our template design services please contact sales@theorem.com quoting "3D PDF Template Design".

Default Publishing

Default Publishing – via the Unified Interface

The Unified Interface can be started via the Start Menu or desktop – if shortcuts were added during installation.

Alternatively, the Unified Interface can be run via a Windows Explorer selection in:

```
<UI_installation_directory>\bin\Unified_Interface.cmd
```

The following interface will be launched:

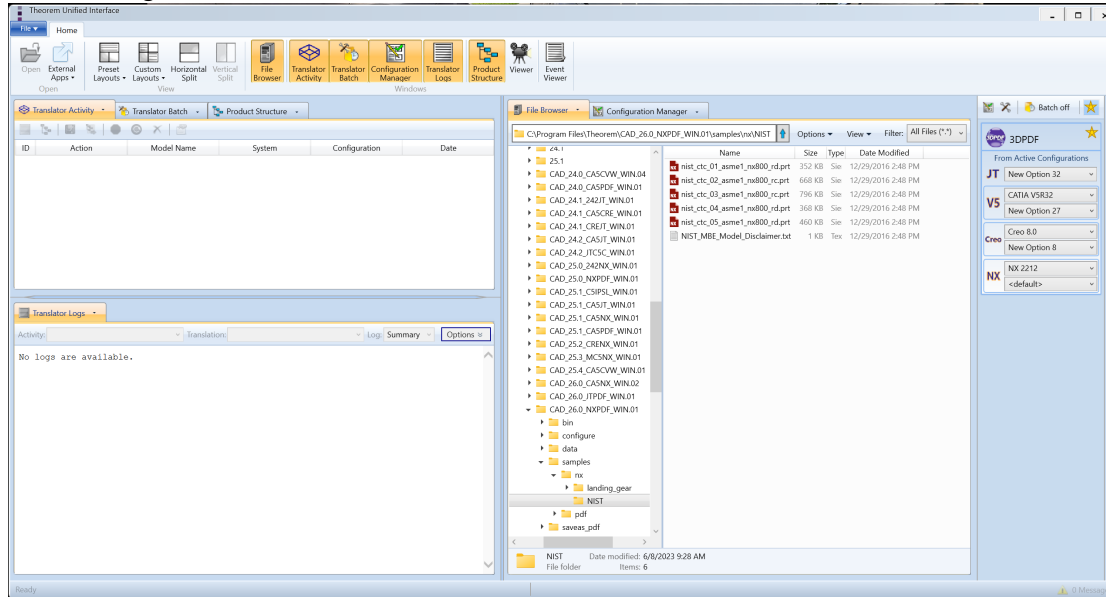

The default layout is split into 4 primary areas, which can be altered to the user’s preference:

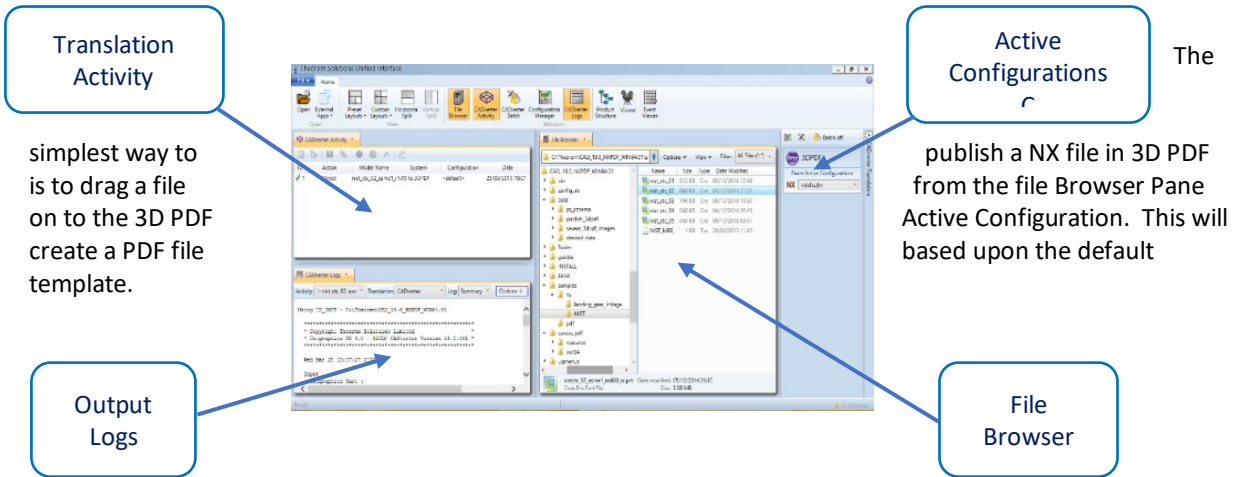

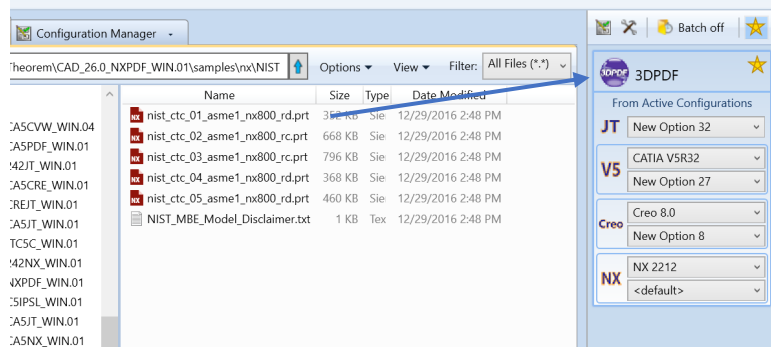

On completion, the Unified Interface will display the activity information and details from the log file created during the translation, if requested, in the Translation Activity and Output Log panes, respectively. The generated output data can be located by selecting the translation from the Activity pane and opening the output folder:

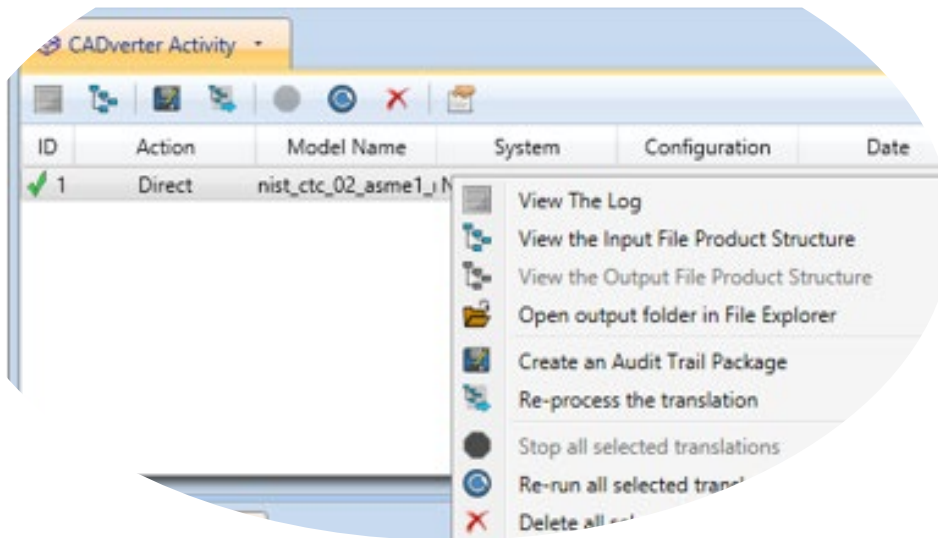

Default Publishing – via the Command Line

Running a translation via the command line can be carried out via the **cad_run.cmd** file located in the **<installation_directory>\bin** directory. The format of the command is as follows (Note! Replace the [version] from the example with your version of NX, e.g. NX 2306):

<Translator_installation_directory>\bin\cad_run.cmd NX[version] 3DPDF -I <input_file> -o <output_file>

```
U:\>"C:\Program Files\Theorem\CAD_26.0_NXPDF_WIN.01\bin\nx2212_3dpdf.cmd" "C:\Program Files\Theorem\CAD_26.0_NXPDF_WIN.01\samples\nx\NIST\nist_ctc_02_asme1_nx800_rc.prt" C:\Temp\nist_ctc_02_asme1_nx800_rc.pdf
```

The example above will translate a sample file provided within the installation and produce the following screen output:

```
U:\>"C:\Program Files\Theorem\CAD_26.0_NXPDF_WIN.01\bin\nx2212_3dpdf.cmd" "C:\Program Files\Theorem\CAD_26.0_NXPDF_WIN.01\samples\nx\NIST\nist_ctc_02_asme1_nx800_rc.prt" C:\Temp\nist_ctc_02_asme1_nx800_rc.pdf
Using TS_INST = C:\Program Files\Theorem\CAD_26.0_NXPDF_WIN.01\

*****
* Copyright Theorem Solutions Limited *
* Siemens NX(2212) - 3DPDF CADverter Version 26.0.001 *
*****

Thu Jun  8 09:40:20 2023

Input
NX Part      : C:\Program Files\Theorem\CAD_26.0_NXPDF_WIN.01\samples\nx\NIST\nist_ctc_02_asme1_nx800_rc.prt
3DPDF File   : C:\Temp\nist_ctc_02_asme1_nx800_rc.pdf
Progress File: C:\Users\bpittman\AppData\Local\Temp\tscprogress5A.log

PUBLISH STD, no Default.xml found, try defaultManifest

Mode      : PUBLISH
Master XML : C:\Program Files\Theorem\CAD_26.0_NXPDF_WIN.01\data\publish_3dpdf\defaultManifest.xml
Template File : C:\Program Files\Theorem\CAD_26.0_NXPDF_WIN.01\data\publish_3dpdf\templates\publishDefault\template.pdf

List of gco entities :-
-----
Type      Total  Standalone  Subordinate
-----
Points    12      12          0
Arcs      1        1          0
Lines     49      49          0
Curves   1534    1534        0
Surfaces  534     534         0
Planes    129     129         0
```

The file will be output to the target location. In this case:

C:\Temp\nist_ctc_02_asme1_nx800_rc.pdf

Publishing to Specific List of Templates

Publishing to Targeted Templates – via the Unified Interface

It is possible to publish to an individual or multiple templates via one translation run using the Unified Interface. In order to do this, a new configuration will be required.

The Configuration Manager pane can be launched via the Active Configuration Pane or from the Ribbon Configuration Manager button:

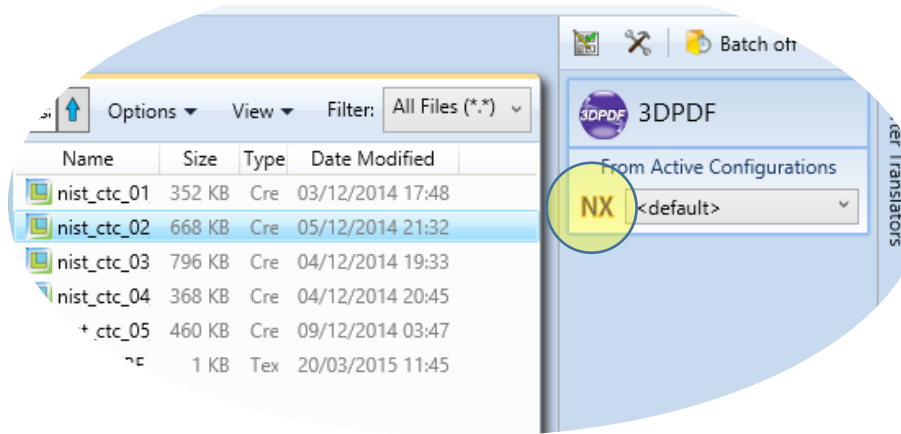

OR

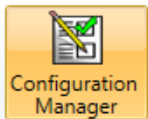

Select the 'Configuration Manager' option from the ribbon menu at the top of the Unified Interface. This will then display the 'Configuration Manager' pane.

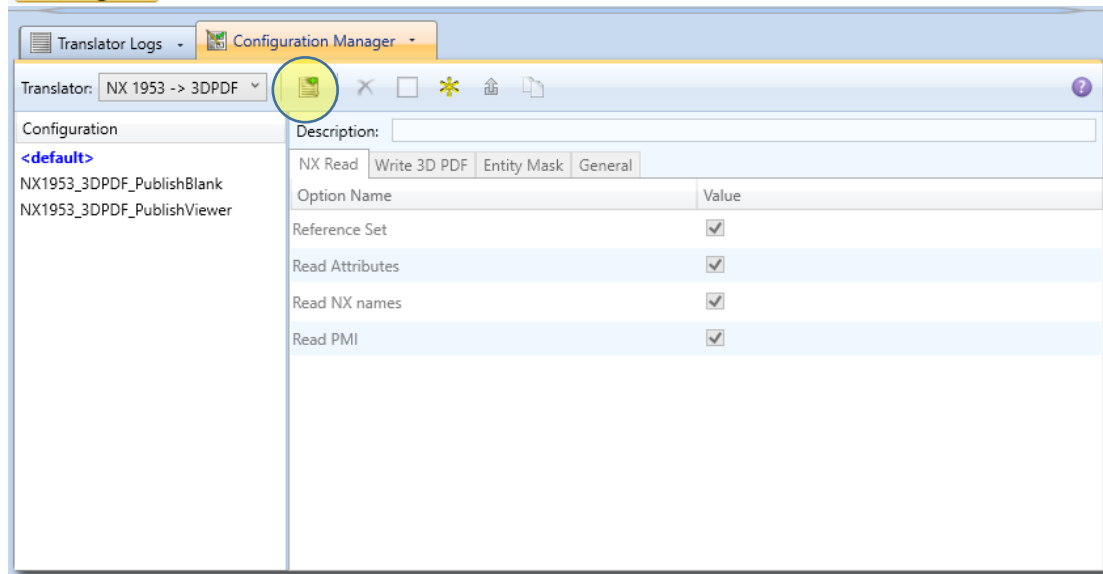

The Configuration Pane allows new configurations to be created based upon ALL available arguments within the Publish 3D application. Selecting the New Configuration icon will allow the user to change any Publish 3D argument.

The panels below show the required selections to create a Configuration to create output based upon Multiple Templates (Note! The same method is used to target an individual template, by selected only one template):

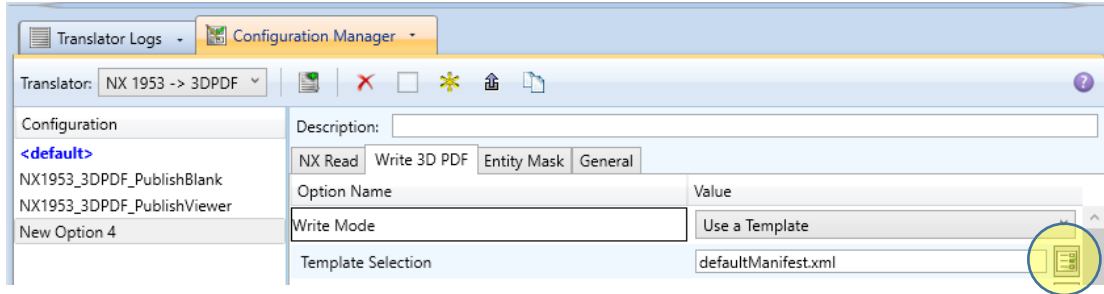

This will open a new selection window. Use the 'Add File' button on the right hand side of the window to select your templates

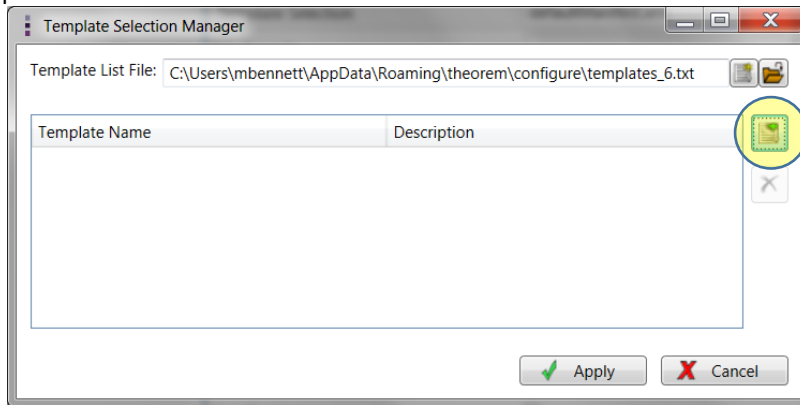

Now select your XML manifest files from the file browser and add them to your selection.

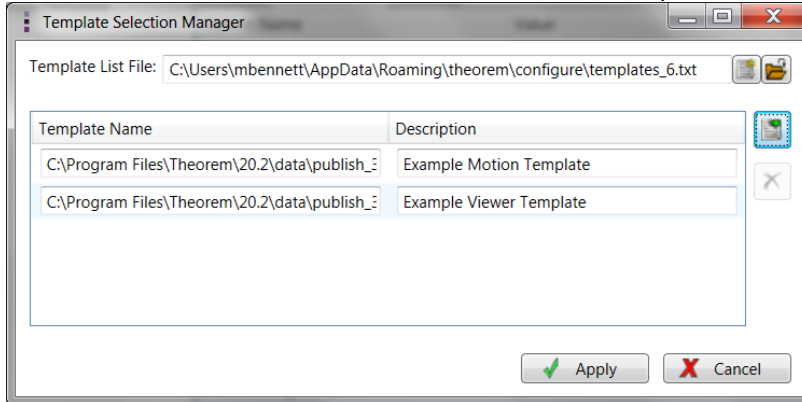

In order to run a translation using this configuration the Active Configuration setting for NX to 3D PDF must be changed to The "Multiple Template Output" Configuration:

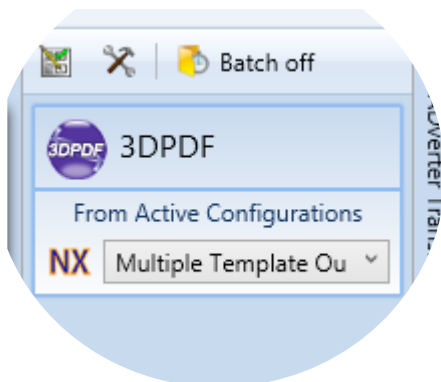

Once this has been done the translation can be invoked in the same manner as for the Default publishing mechanism

Publishing to Targeted Templates – via the Command Line

Publishing to an individual template or multiple templates can also be achieved via the command line interface.

First a list of target Manifest files that describe how to use a template must be created. (Note! For further information regarding our template design services please contact sales@theorem.com quoting “3D PDF Template Design”.)

The list is provided via a text file in the following format:

```
<Translator_installation_directory>\data\publish_3dpdf\templates\publishViewer.xml
<Translator_installation_directory>\data\publish_3dpdf\templates\publishRFQ.xml
```

Note! Each line points to an XML manifest file, examples of which are provided in the Publish 3D installation.

Note! Each line points to an XML manifest file, examples of which are provided in the Publish 3D installation.

Once this file has been created the syntax for running a command to publish to multiple templates is as follows (Note! Replace the [version] from the example with your version of NX, e.g. NX1953):

```
<Translator_installation_directory>\bin\cad_run.cmd NX[version]_3DPDF
<input_file> <output_file> publish <manifest list>
```

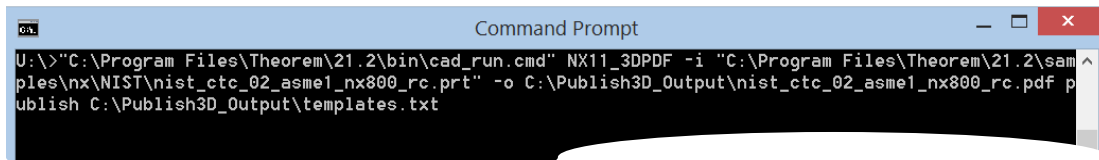

The example above will use the referenced template manifest list and will publish an output to each of the templates referenced via the manifest files provided, whether there be one or many in the list. The following screen output should be expected, producing one “Create Artwork” line per template:

```

*****
* Copyright Theorem Solutions Limited *
* Unigraphics NX11.0 - 3DPDF CADverter Version 20.2.001 *
*****

Wed Nov 15 14:03:39 2017

Input
Unigraphics Part :
C:\Program Files\Theorem\20.2\samples\nx\NIST\nist_ctc_02_asme1_nx800_rc.prt
3DPDF File : C:\Publish3D_Output\nist_ctc_02_asme1_nx800_rc.pdf
Progress File : C:\Users\rdujmore\AppData\Local\Temp\tescprogress5A.log

Mode : PUBLISH
Master LIST : C:\Publish3D_Output\templates.txt

Mode : PUBLISH
Master XML : C:\Program Files\Theorem\20.2\data\publish_3dpdf\templates\publishViewer.xml
Template File : C:\Program Files\Theorem\20.2\data\publish_3dpdf\templates\publishViewer\templa
te.pdf

List of gco entities :-
-----
Type      Total      Standalone  Subordinate
-----
Points    12          12
Arcs      1           1
Lines     49          49
Curves   1521        1521
Surfaces  534         534
Planes    129         129
Faces     663         663
Edges     1521        1521
Vertices  955         955
Boollide  1           1
Axis systems 4           4
Details   18          18
Dittos    18          1       17
Dimensions 7           7
Texts     1           1
GDT       22          22
Datum     15          15
3D Views  4           4
-----

Create Artwork ...
Display Views ...
Display Scroll List ...
Button button_PrintDocument(0,0) ...
Button button_HideShowToolBar(0,0) ...
Button button_HideShowModelTree(0,0) ...
Text DisplayCtrl(0,0) ...
Button button_PHTOnOff(0,0) ...
Button button_HideSelectedGeom(0,0) ...
Button button_HideUnSelectedGeom(0,0,"transparent") ...
Button button_ShowAllGeom(0,0) ...
Button button_Explode Assy(0,0) ...
Button button_SearchPartFilter(0,0) ...
Button button_SearchPartFilterReset(0,0) ...
*****
* 3DPDF file successfully created *
* C:\Publish3D_Output\nist_ctc_02_asme1_nx800_rc_publishViewer.pdf *
*****
Ignoring 'attach file' line : Select a file from list

Mode : PUBLISH
Master XML : C:\Program Files\Theorem\20.2\data\publish_3dpdf\templates\publishRF0.xml
Template File : C:\Program Files\Theorem\20.2\data\publish_3dpdf\templates\publishRF0\templat
e.pdf

List of gco entities :-
-----
Type      Total      Standalone  Subordinate
-----
Points    12          12
Arcs      1           1
Lines     49          49
Curves   1521        1521
Surfaces  534         534
Planes    129         129
Faces     663         663
Edges     1521        1521
Vertices  955         955
Boollide  1           1
Axis systems 4           4
Details   18          18
Dittos    18          1       17
Dimensions 7           7
Texts     1           1
GDT       22          22
Datum     15          15
3D Views  3           3
-----

Create Artwork ...
Display Selection Box ...
*****
* 3DPDF file successfully created *
* C:\Publish3D_Output\nist_ctc_02_asme1_nx800_rc_publishRF0.pdf *
*****

Mode : PUBLISH_2D
Master XML : C:\Program Files\Theorem\20.2\data\publish_3dpdf\templates\publishMulti.xml
Template File : C:\Program Files\Theorem\20.2\data\publish_3dpdf\templates\publishMulti\templat
e.pdf

*****
* 3DPDF file successfully created *
* C:\Publish3D_Output\nist_ctc_02_asme1_nx800_rc.pdf *
*****
* 3DPDF file successfully created *
* C:\Publish3D_Output\nist_ctc_02_asme1_nx800_rc.pdf *
*****
JG->3DPDF returning completion code 0
Closing progress file - Completed

```

Publishing without a Template

Publishing without a Template – via the Unified Interface

To run Publish 3D without a template in the Unified Interface, navigate to the configuration manager as described, and from the ‘Write Mode’ option in the ‘Write 3D PDF’ tab, select ‘No Template’. Save this configuration as previously described, you are now ready to publish without using a template.

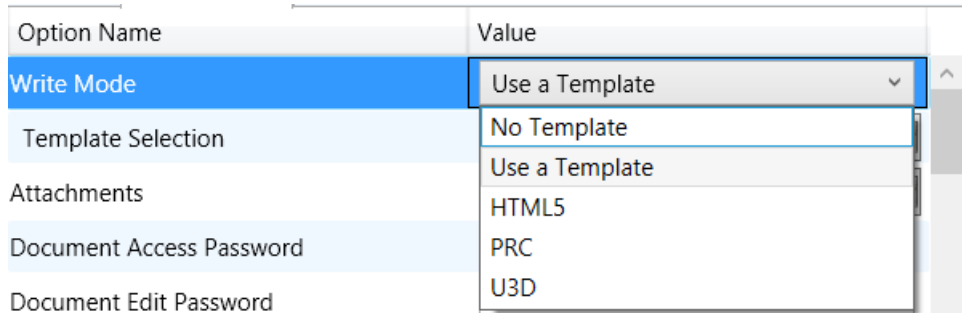

Now, in the ‘Active Configurations’ pane select your configuration from the menu and then ‘drag and drop’ your data to publish it to a PDF document.

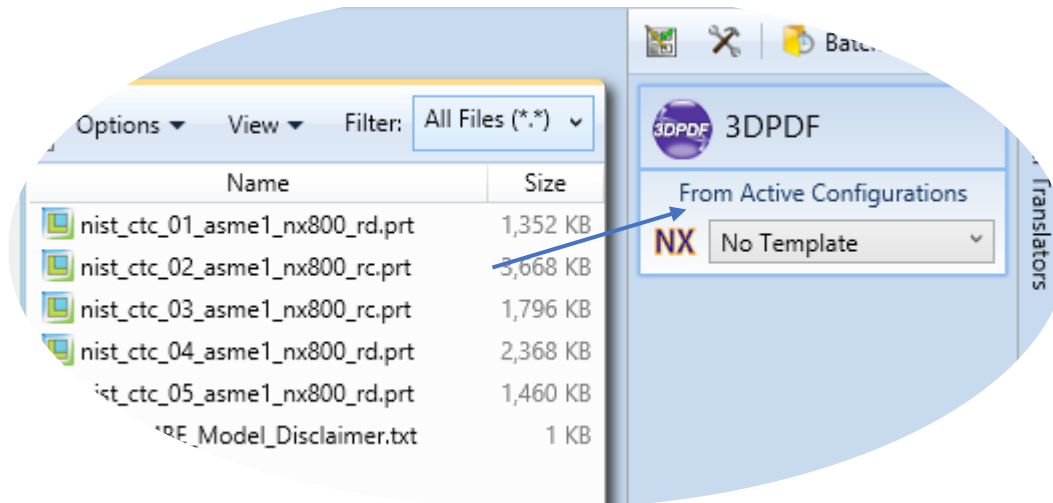

On completion, the Unified Interface will display the activity information and details from the log file created during the translation, if requested, in the Translation Activity and Output Log panes, respectively. The generated output data can be located by selecting the translation from the Activity pane and opening the output folder:

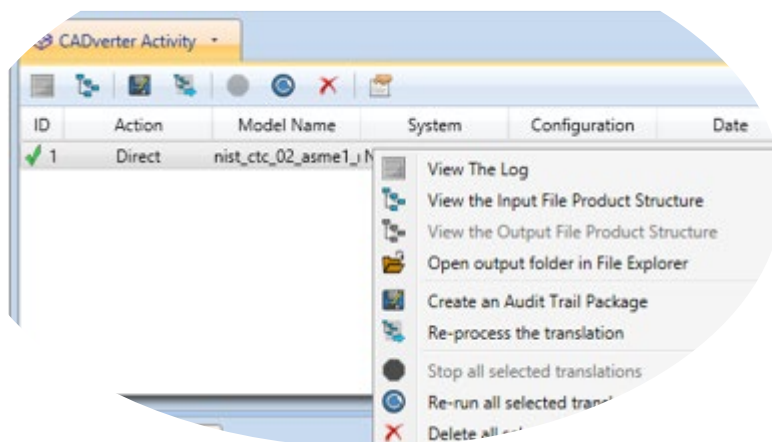

Publishing without a Template – via the Command Line

Publishing without a template can also be achieved via the command line interface.

The syntax for running a command to publish without a template is as follows (Note! Replace the [version] from the example with your version of NX, e.g. NX9):

```
<Translator_installation_directory>\bin\cad_run.cmd NX[version]_3DPDF
<input_file> <output_file> publish off
```

```
Microsoft Windows [Version 10.0.22621.3296]
(c) Microsoft Corporation. All rights reserved.

U:\>"C:\Program Files\Theorem\cdCAD_27.0_NXPDF_WIN.01\bin\nx2312_3dpdf.cmd" "C:\Temp\QA_Testing\QA Manual Test Results cdCAD_27.0_NXPDF_WIN.01\test_output\NX_2312_PDF\cmd\nist_ctc_01_asme1_nx800_rd.prt" "C:\Temp\QA_Testing\QA Manual Test Results cdCAD_27.0_NXPDF_WIN.01\test_output\NX_2312_PDF\cmd\OUT\nist_ctc_01_asme1_nx800_rd.pdf"
```

The example above will publish a PDF file containing the model data without any formatting. The following screen output should be expected

```
Microsoft Windows [Version 10.0.22621.3296]
(c) Microsoft Corporation. All rights reserved.

U:\>"C:\Program Files\Theorem\cdCAD_27.0_NXPDF_WIN.01\bin\nx2312_3dpdf.cmd" "C:\Temp\QA_Testing\QA Manual Test Results cdCAD_27.0_NXPDF_WIN.01\test_output\NX_2312_PDF\cmd\nist_ctc_01_asme1_nx800_rd.prt" "C:\Temp\QA_Testing\QA Manual Test Results cdCAD_27.0_NXPDF_WIN.01\test_output\NX_2312_PDF\cmd\OUT\nist_ctc_01_asme1_nx800_rd.pdf"
Using TS_INST = C:\Program Files\Theorem\cdCAD_27.0_NXPDF_WIN.01\

*****
* Copyright Theorem Solutions Limited
* Siemens NX(2312) - 3DPDF CADverter Version 27.0.001 *
*****

Tue Apr 2 09:31:18 2024

Input
NX Part      : C:\Temp\QA_Testing\QA Manual Test Results cdCAD_27.0_NXPDF_WIN.01\test_output\NX_2312_PDF\cmd\nist_ctc_01_asme1_nx800_rd.prt
3DPDF File  : C:\Temp\QA_Testing\QA Manual Test Results cdCAD_27.0_NXPDF_WIN.01\test_output\NX_2312_PDF\cmd\OUT\nist_ctc_01_asme1_nx800_rd.pdf
Progress File : C:\Users\bpittman\AppData\Local\Temp\tscprogressSA.log

ERRORR : Exception thrown in 'set_display_part_opt' : Message : No Gateway license to obtain an NXOpen Session. Code : 3615094

Mode       : PUBLISH
Master XML : C:\Program Files\Theorem\cdCAD_27.0_NXPDF_WIN.01\data\publish_3dpdf\templates\Default.xml
Template File : C:\Program Files\Theorem\cdCAD_27.0_NXPDF_WIN.01\data\publish_3dpdf\templates\template_media\Default\template.pdf

List of gco entities :-
-----
Type      Total  Standalone  Subordinate
-----
Points    1          1
Lines     12         12
Curves   414        414
Surfaces  71          71
Planes    88          88
Faces     151        151
Edges     414        414
Vertices  270        270
Bsolids   1           1
Axis systems 1          1
Details   5           5
Dittos    5           1          4
Dimensions 10         10
Texts     2           2
GDT       6           6
Datum     3           3
3D Views  1           1

Create Artwork ...
*****
* 3DPDF file successfully created
*****
* C:\Temp\QA_Testing\QA Manual Test Results cdCAD_27.0_NXPDF_WIN.01\test_output\NX_2312_PDF\cmd\OUT\nist_ctc_01_asme1_nx800_rd.pdf *
NX->3DPDF returning completion code 0
Closing progress file - Completed
```

Translator Customization

Publish 3D allows the information that is read from the source system and written to the target system to be tailored via a set of user specified arguments. Commonly used arguments are supported via the Unified Interface, with Advanced Arguments being described within this document for use in the Unified Interface or via the Command Line invocation.

Common Options for NX Publishing

Within the Configuration Manager pane of the Unified Interface, arguments that can be specified when publishing NX data into 3D PDF are grouped into 3 areas:

- **NX Read** – Those arguments that affect how data is read from NX
- **Write 3D PDF** – Those arguments that affect how the data is written to 3D PDF
- **Entity Masking** – Those arguments that allow specific entities to be masked
- **General** – Those arguments that are common to ALL Publishing activities
regardless of source data

The image below shows the NX Read arguments that are available, with their default settings:

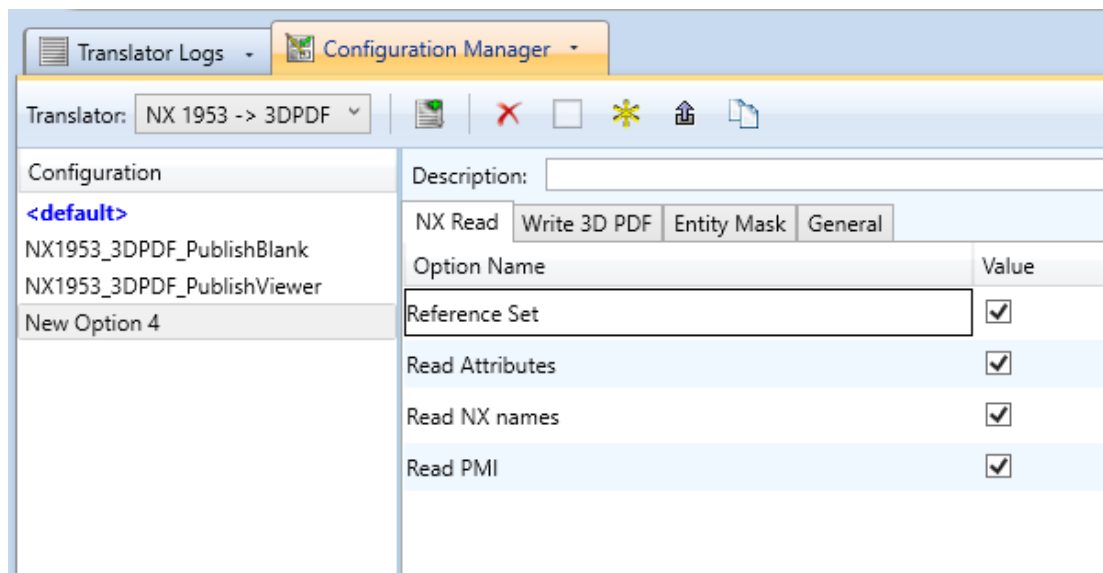

Each of these options is described below:

Option	Description
Reference Set	Enables Reference Set processing. <i>(Default is on).</i> <ul style="list-style-type: none"> ○ Command Line Syntax: <ul style="list-style-type: none"> ▪ <i>no_ref_set</i> – to turn off
Read Attributes	Enables NX Attribute processing. <i>(Default is on).</i> <ul style="list-style-type: none"> ○ Command Line Syntax:

	<ul style="list-style-type: none"> ▪ <i>no_read_attrs</i> – to turn off
Read NX Names	<p>Read NX Entity Names, if they exist. (Default is on).</p> <ul style="list-style-type: none"> ○ Command Line Syntax: <ul style="list-style-type: none"> ▪ <i>no_read_name</i> – to turn off
Read PMI	<p>Read 3D PMI. (Default is on).</p> <ul style="list-style-type: none"> ○ Command Line Syntax: <ul style="list-style-type: none"> ▪ <i>no_read_pmi</i> – to turn off

The image below shows the Write 3D PDF arguments that are available, with their default settings:

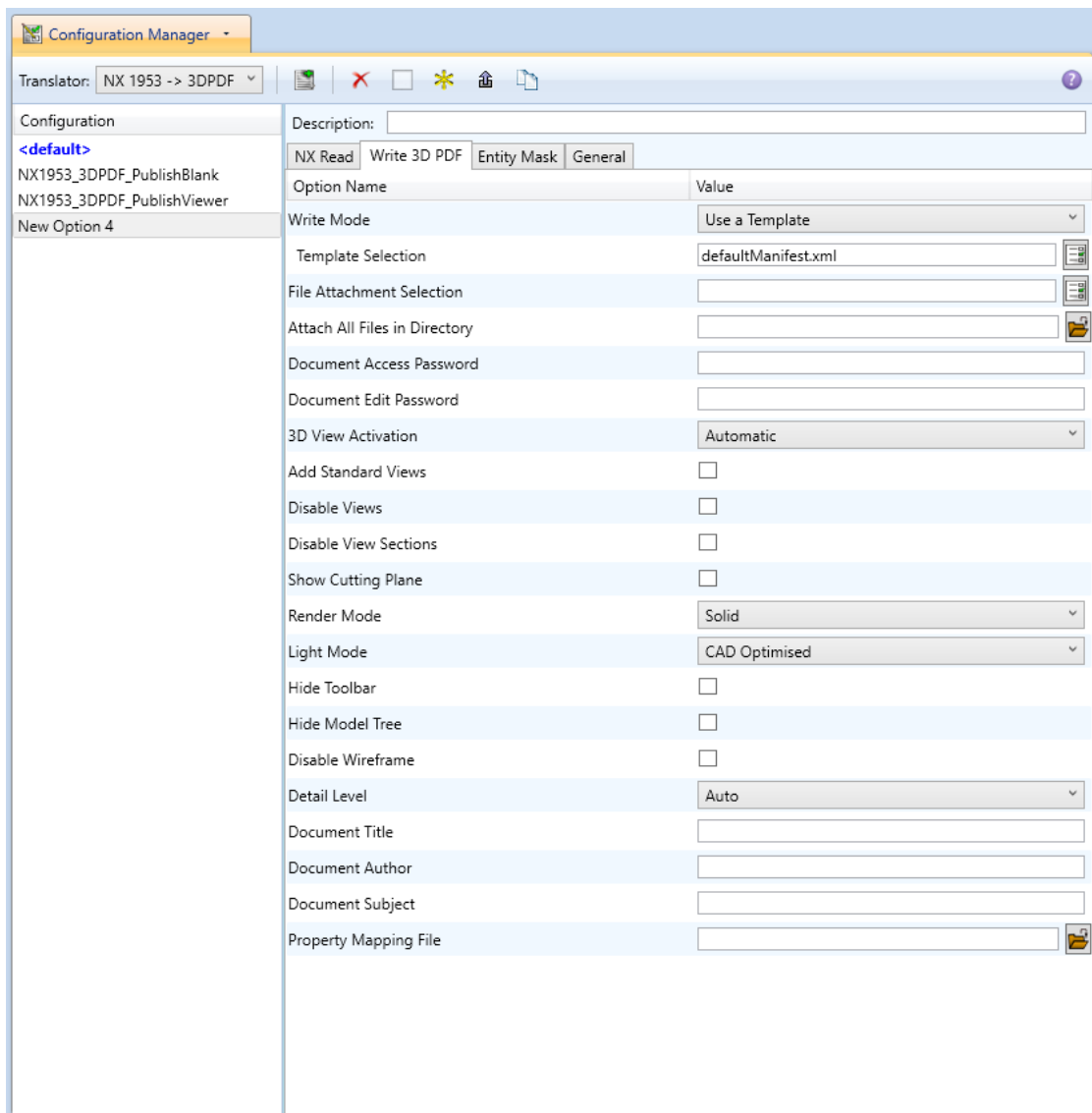

Each of these options is described below:

Option	Description
Write Mode	Contains 5 options: <ul style="list-style-type: none"> • Use a Template – Allows data to be published to a given template (<i>Default</i>) <ul style="list-style-type: none"> ○ Command Line Syntax: <ul style="list-style-type: none"> ▪ <i>Publish std <list of Manifest files></i> • No Template – No template will be used during publishing. If this option is selected, ‘Template Selection’ is excluded as an option. <ul style="list-style-type: none"> ○ Command Line Syntax: <ul style="list-style-type: none"> ▪ <i>Publish off</i> • HTML5 - This will create a HTML5 file which contains the 3D data <ul style="list-style-type: none"> ○ Command Line syntax: <ul style="list-style-type: none"> ▪ <i>Publish HTML5</i> • PRC – This will create a PRC file containing the 3D Data <ul style="list-style-type: none"> ○ Command Line Syntax <ul style="list-style-type: none"> ▪ <i>Publish PRC</i> • U3D – This will create a U3D file containing the 3D Data <ul style="list-style-type: none"> ○ Command Line Syntax <ul style="list-style-type: none"> ▪ <i>Publish U3D</i>
Template Selection	Select which templates Publish 3D will use to create the output 3D PDF, if Write Mode is set to <i>Use a Template (Default = defaultManifest.xml)</i> <ul style="list-style-type: none"> • Command Line Syntax: <ul style="list-style-type: none"> ○ <i>This is a secondary argument to the publish command. The argument can be a single xml manifest file to a text file containing a list of manifest files</i>
File Attachments	This option allows files to be attached to the output PDF file together with a brief description of the selected files. (<i>Default is for no files to be attached</i>) <ul style="list-style-type: none"> • Command Line Syntax: <ul style="list-style-type: none"> ○ <i>Attach_file <Attachment List></i>

	<p>Where <i>Attachment_List</i> is a list of full path names to file followed by an optional description line: e.g.</p> <pre>C:\TEMP\my_image.jpg This is a jpg Image C:\TEMP\report.txt Report Document C:\TEMP\related.pdf C:\TEMP\another.pdf This PDF has a description</pre> <p>Note in this example the 'Related.pdf' attached file doesn't have the optional comment. The file path may contain environment variables which will be resolved. e.g. %TEMP%/myFile.pdf</p>
<p>Attach all files in directory</p>	<p>Attach the files found in specified directory:</p> <ul style="list-style-type: none"> • Command line syntax: <pre>attach_files_in_dir %your_directory_path%</pre>
<p>Document Access Password</p>	<p>If a password is provided in the text field:</p> <ul style="list-style-type: none"> • Allow a password to be specified to encrypt the PDF document. If specified, the user will be prompted for the password to open the resultant PDF files <ul style="list-style-type: none"> ○ Command Line Syntax: <ul style="list-style-type: none"> ▪ <code>password <password></code>
<p>Document Edit Password</p>	<p>If a password is provided in the text field (<i>Note! This password MUST be different from the Document Access Password to enable Document Edit Permissions to be honoured</i>):</p> <ul style="list-style-type: none"> • Use Password – Allow a password to be specified to controls edits to the PDF Document. <ul style="list-style-type: none"> ○ Command Line Syntax: <ul style="list-style-type: none"> ▪ <code>permission_password <password></code>
<p>3D View Activation</p>	<p>Specifies how the 3D view in the resultant 3D PDF file is activated (<i>Default is On Selection</i>) <i>Options are:</i></p> <ul style="list-style-type: none"> ○ <i>Automatic</i> ○ <i>On Selection</i> ○ <i>Page Visible</i> • Command Line Syntax: <ul style="list-style-type: none"> ○ <code>activate_mode PAGE_OPEN (for Automatic)</code>

	<ul style="list-style-type: none"> ○ <i>activate_mode CLICK (for On Selection)</i> ○ <i>activate_mode PAGE_VISIBLE (for Page Visible)</i>
Add Standard Views	<p>Add isometric views to the data being written to PDF (<i>Default is off</i>)</p> <ul style="list-style-type: none"> ○ Command Line Syntax: <ul style="list-style-type: none"> ▪ <i>add_standard_views</i>
Disable Views	<p>Switch off any Captures/Views from being written into the PDF. (<i>Default is off</i>)</p> <ul style="list-style-type: none"> ○ Command Line Syntax: <ul style="list-style-type: none"> ▪ <i>no_views</i>
Disable View Sections	<p>Switch off any sections within the Captures/Views from being written into the PDF. (Default is off)</p> <ul style="list-style-type: none"> ○ Command Line Syntax: <ul style="list-style-type: none"> ▪ <i>no_sections</i>
Show Cutting Plane	<p>Enable cut plane visualization. (Default is off)</p> <ul style="list-style-type: none"> ○ Command Line Syntax: <ul style="list-style-type: none"> ▪ <i>cutplane_on</i>
Render Mode	<p>Controls which Rendering Mode to use for the model. Options are:</p> <ul style="list-style-type: none"> • Solid (<i>Default</i>) • Transparent • Wire • Illustrated • Outline • Shaded ○ Command Line Syntax: <ul style="list-style-type: none"> ▪ <i>Render_mode <mode></i> <p style="text-align: center;">Where mode is set to one of the above values</p>
Light Mode	<p>Controls which Light Mode to use. Options are:</p> <ul style="list-style-type: none"> • Default • Off

	<ul style="list-style-type: none"> • Day • Bright • Prim • Night • Blue • Red • Cube • Head <ul style="list-style-type: none"> ○ Command Line Syntax: <ul style="list-style-type: none"> ▪ <i>light_mode <mode></i> <p>Where mode is set to one of the above values. Note! No command is required for the default value.</p>
Hide Toolbar	<p>Hide the 3D Toolbar in the resultant document. This can be re-enabled in Adobe if required. <i>(Default is off)</i></p> <ul style="list-style-type: none"> ○ Command Line Syntax: <ul style="list-style-type: none"> ▪ <i>hide_toolbar</i>
Hide Model Tree	<p>Hide the Model Tree in the resultant document. This can be re-enabled in Adobe if required. <i>(Default is off)</i></p> <ul style="list-style-type: none"> ○ Command Line Syntax: <ul style="list-style-type: none"> ▪ <i>hide_model_tree</i>
Disable Wireframe	<p>Disable Wireframe Processing <i>(Default is to Enable Wireframe processing)</i></p> <ul style="list-style-type: none"> ○ Command Line Syntax: <ul style="list-style-type: none"> ▪ <i>process_wf off</i>
Detail Level	<p>The Detail Level option can be used to set the render quality of the resultant 3D PDF output. A number of discrete values are made available via the UI. They correspond to a relative chordal deviation (% of the diagonal length across the model bounding box) or absolute chordal deviation, whichever is the smaller. The following options are available:</p> <ul style="list-style-type: none"> • Auto (Corresponds approximately to High) • Very High (relative = 0.0001%, absolute = 0.001mm)

	<ul style="list-style-type: none"> • High (relative = 0.001%, absolute = 0.01mm) • Medium (relative = 0.01%, absolute = 0.1mm) • Low (relative = 0.1%, absolute = 1mm) • Very Low (relative = 0.5%, absolute = 5mm) • Ultra_Low (relative = 2.0%, absolute = 25mm) <ul style="list-style-type: none"> ▪ for very large plant data <p>For very large (detailed) parts the use of this option (Low or Very Low) can significantly reduce the size of the output PDF file and the time taken to produce it, at the cost of quality.</p> <p>A setting of Medium is seen as a good compromise, between quality and size. This value is the default value.</p> <ul style="list-style-type: none"> ○ Command Line Syntax: <ul style="list-style-type: none"> ▪ <i>lod_level <value></i> <p style="text-align: center;"><i>Where value = ultra_low, v_low, low, med, high, v_high, off</i></p>
Document Title	Set the Document Properties 'title' field. <ul style="list-style-type: none"> ○ Command Line Syntax: <ul style="list-style-type: none"> ▪ <i>doc_description_title <text></i> <ul style="list-style-type: none"> • the text should be quoted
Document Author	Set the Document Properties 'author' field <ul style="list-style-type: none"> ○ Command Line Syntax: <ul style="list-style-type: none"> ▪ <i>doc_description_author <text></i> <ul style="list-style-type: none"> • the text should be quoted
Document Subject	Set the Document Properties 'subject' field <ul style="list-style-type: none"> ○ Command Line Syntax: <ul style="list-style-type: none"> ▪ <i>doc_description_subject <text></i> <ul style="list-style-type: none"> • the text should be quoted
Property Mapping File	Allows a user to define how properties can be mapped from NX to the output PDF. <ul style="list-style-type: none"> ○ Command Line Syntax:

- *cad_prop_map_file <prop_file_text>*

Sample in %Install_dir%\data\publish_3dpdf\attrFilters\defaultAttrFilter.txt

The image below shows the Masking arguments that are available, with their default settings:

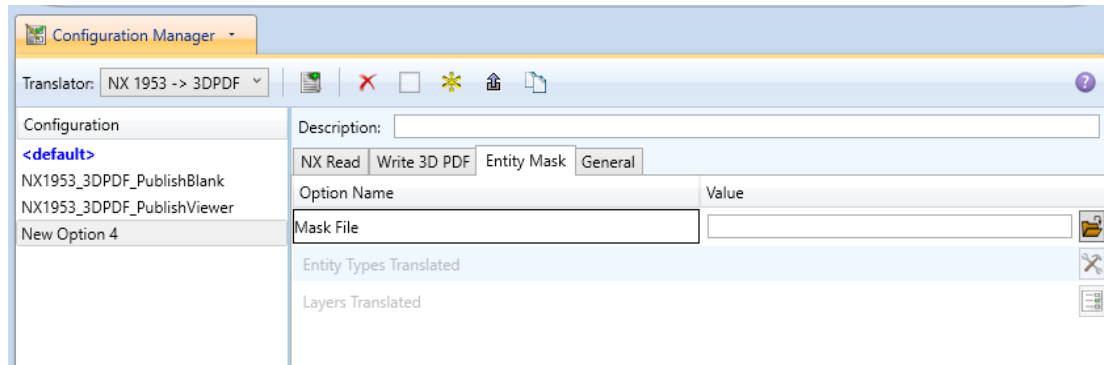

Each of these options is described below:

Option	Description
Mask File	<p>Specifies the Mask File to be written to, that can be referenced by future translations. A Mask file MUST be specified if masking is required. The first line in this file is OFF ALL ENT:</p> <ul style="list-style-type: none"> ○ Command Line Syntax: <ul style="list-style-type: none"> ▪ <i>Mask <filename></i>
Entity Types Translated	<p>Specifies a selection list from which to select which entity types are to be processed. The following types are available: "POI","LIN","ARC","CON","CUR","SUR","FAC","SOL","TEX","AXI"</p> <ul style="list-style-type: none"> ○ Command Line Syntax: <ul style="list-style-type: none"> ▪ <i>Add any of the above to the specified mask file, one entry per line prefixed by the word ON, e.g.:</i> <p>ON POI <i>to ensure they are considered in the translation</i></p>
Layers Translated	<p>Specifies a selection list from which to select which layers are to be processed.</p> <ul style="list-style-type: none"> ○ Command Line Syntax: <ul style="list-style-type: none"> ▪ <i>A single entry of ON ALL LAY Must precede any Layer Mask command.</i>

- Add a list or range of numbers representing layer to be processed to the specified mask file to ensure they are NOT considered in the translation

e.g.:

OFF LAY 114,149,166,167,168

The image below shows the General arguments that are available, with their default settings:

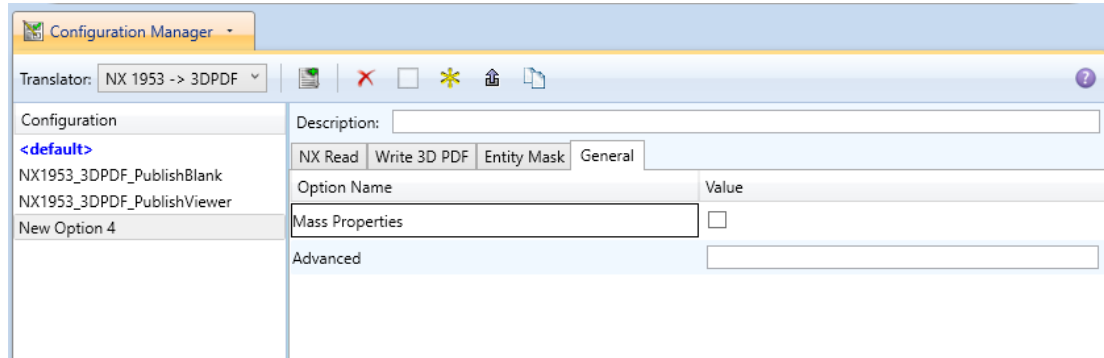

Each of these options is described below:

Option	Description
Mass Properties	Allows Mass Property information to be read from the source data and written as attributes to the PDF document (<i>Default is off</i>) <ul style="list-style-type: none"> ○ Command Line Syntax: <ul style="list-style-type: none"> ▪ <i>mprops</i>
Advanced	Allows any of the Command Line Advanced arguments documented below to be passed to the Unified Interface invocation

Command Line Advanced Arguments

Any of the Advanced arguments can be added to the Command Line Invocation or to the General->Advanced field when run from within the User Interface.

NX Advanced Arguments

Argument	Description
all_layers	Read entities from ALL layers even if the layer is invisible
fit_view	Fits the visible geometry to the screen size (e.g. zooms the view), regardless of users source system settings.

	The default option is <i>'fit_view_as_saved'</i> , which reads the view according to the settings in the source CAD system.
heal_ug_read	Attempt an NX heal on the (native) body - using the NX API. Note! This should be used in combination with <i>regen_brep</i>
part_layer	If set, Process As Saved part layers. If unset process All layers
read_blank	Reads any blanked entities. (<i>Default is off</i>)
read_assy_pmi	Allows assembly component level PMI to be read. (<i>Default is off</i>)
read_views	<p>This flag turns on the processing of 3D Views even if <i>'read_pmi'</i> is off.</p> <p>If <i>'read_pmi'</i> is ON, then <i>'read_views'</i> is switched ON automatically. This can be overridden by specifying <i>'no_read_views'</i></p> <p>If <i>'read_pmi'</i> is OFF, then <i>'read_views'</i> is OFF by default. This can be overridden by specifying <i>'read_views'</i></p>
ref_set_part_name	If set, append the Reference Set name to created part
regen_brep	Allows brep data to be regenerated from the topology using the NX API. Note! It is only advised to use this option if solid information cannot be written into 3D PDF.
no_create_datum_plane_border	<p>Disables the creation of datum plane borders.</p> <p>The default is to create 4 datum plane bounding lines to mimic NX section lines</p>
read_arrangements	Reading of NX assembly arrangements (Default is Off)
read_translucency	Reading of NX face/body translucency (Default is Off)
publish_for_disclosure_views_filter	Using this additional option ensures that only the views that have the attribute "publish for disclosure" flag set to "True" are processed from the input file to the output PDF
ignore_std_views_off	Reads all of the NX standard views
no_keep_trim_bodies	Using this option allows you to retain trimmed bodies on the sectioned side of a section view.

3DPDF Advanced Arguments

Argument	Description
<i>progress_file</i> <filename>	Specify the log file for this process.
<i>info</i>	Add 'info' messages to the log file.
<i>no_inst_colours</i>	Switch off the writing of instance colours.
<i>no_colours</i>	Switch off the writing of any colours.
<i>no_attrs</i>	Switch off the writing of attributes into the PDF.
<i>no_pmi_edge_associations</i>	Disables edge highlighting
<i>no_poster</i>	By default a 2D poster is generated from the 3D model which can be very time consuming for a complex model. This option disables that process and uses a default JPG called TS_INST\data\saveas_3dpdf_images\no_poster.jpg . The user could replace this JPG file with their own if desired.
<i>background_RGB</i> <r g b>	Where r g b are values 1 to 255, this controls the background colour of the 3D display, which now defaults to pale grey (204,204,204).
<i>pmi_RGB</i> <r g b>	Where r g b are values 1 to 255, this controls the override PMI colour. By default PMI is displayed in the same colour as the source CAD system. When a colour is not read the default will be black. This option allows the PMI colour to be fixed to any colour, clearly this is a single override colour for all PMI.
<i>wireframe_RGB</i> <r g b>	Where r g b are values 1 to 255, this controls the override PMI colour. By default wireframe is displayed in the same colour(s) as the source CAD system. This option allows the wireframe colour to be fixed to any colour, clearly this is a single override colour for all PMI.
<i>process_wf</i> <value>	Where value = tess_low,tess_med,tess_high, nurb or off When this option is selected the wireframe entities are written as lines/conic/nurbs. This results in a wire node for each entity

	<p>contained under the Wireframe node in the model tree, there could be many wire nodes in a complex model.</p> <p>If any of the settings prefixed tess are used, these options convert wireframe into a number of sampled points on the curve and writes wireframe as a Poly Line, this allows many wires to be combined. However a Poly Line can only be a single colour, so wireframe of the same colour will be grouped into a Poly Wire, which will be a wire node contained under the Wireframe node in the model tree, there will be a wire node for each colour, when multi colours exist.</p> <p>If however all wireframe is the same colour, all wireframe is contained in the Wireframe node.</p>
<p><i>attr_filter_file <filter file></i></p>	<p>This is a method to define which attributes are masked or included during translation.</p> <p>By default there is an attribute filter file installed at:</p> <p>%TS_INST%\ data\publish_3dpdf\attrFilters\ defaultAttrFilter.txt</p> <p>This command line option allows this file to be overridden, such that the named file is used instead of the default.</p> <p>The file format (in blue) is best explained by means of examples :</p> <p>MPARTNAME,,0,, (Delete MPARTNAME attribute) FILENAME,F I L E (name),1,, (Rename 'FILENAME' to 'F I L E (name)) FILESIZE,,3,big,, (Default (always) FILESIZE value to big) *END,,0,, (Delete all attributes that end with 'END') Theorem*,,0,, (Delete all attributes that start with 'Theorem')</p>
<p><i>dump_attr_file <file></i></p>	<p>This is a utility which can be used to generate a text file with the Key/Value pairs from the GCO DESIGN,DITTO and DETAIL entities, this can be used in the 'design' of templates.</p>
<p><i>hide_empty_node</i></p>	<p>When assembly nodes contain no geometry, (could be due to missing part files) this option results in the model tree with 'un-ticked' nodes where no geometry was read. Where the 3DGeom node would be there will be a NoGeom node.</p> <p>Please node in order to activate this behaviour it was necessary to add a point at 0,0,0 which is contained by the NoGeom node.</p>

<i>compress_tess</i> <value>	<p>Where value = v_low, low,med,high,v_high,off</p> <p>These options can be used to control the tessellation setting, using the values 10,25,50,75,90%. These compression settings apply ONLY to PRC/U3D output files.</p>
<i>add_standard_views_1st</i>	Force views to be first angle projection regardless of source data
<i>add_standard_views_3rd</i>	Force views to be third angle projection regardless of source data
<i>copy_part_attrs</i> <on/off>	Attributes on parts can be copied onto instance nodes with this option (default is off). (<i>The user can enable dump_attr_file <file> option to confirm what attributes are available on part/instances, to check the effect of this option</i>)
<i>cutplane_capping_off</i>	Disable section capping (Default is on)
<i>cutplane_RGB</i> <r g b>	When section cutting planes are enabled, the cutting plane colour can be controlled by r g b values in the range of 1 to 255
<i>cutplane_opacity</i> <val>	When section cutting planes are enabled, the cutting plane opacity can be specified by setting 'val' between 0.0 and 1.0
<i>cutplane_intersections</i>	Section cutting intersections can be enabled via this option. (Default is off)
<i>cutplaneIS_RGB</i> <r g b>	When section cutting plane intersections are enabled, the cutting plane intersection colour can be controlled by r g b values in the range of 1 to 255
<i>enable_brep</i>	By default BREP data is omitted when the PDF file is generated so this options allows for such data to be retain. Do not use this option when the generation of BREP data in PDF is forbidden for legal or commercial reasons.
<i>fixup</i>	There are occasions when the source data presented for publishing to 3D PDF is invalid. In these circumstances, a validation of the data is carried out by the translator and the user is advised, via a message to the screen to re-run the translator, specifying the ' <i>fixup</i> ' command line option. Specifying this option will allow the translation to complete, omitting any faces that are not topologically correct.
<i>fix_inst_names</i> <on/off>	By default this option is on. It will detect instances with no names and apply the part name to those instances. This accommodates cases where instance names are not available in the source data.
<i>launch_adobe_viewer</i>	This option will automatically display the resulting PDF file in an Adobe Reader. The environment variable TS_CMD_PATH_AND_EXE can be used to specify the Adobe application if it isn't found in a default location.
<i>group_solids</i>	This can be useful when data is created with many open solids (1 per face). This can result in many 100's or even 1000's of solids which causes the 3D PDF file to have a massive entity tree, to be

	<p>slower and larger than necessary, and with a Bounding Box for each face.</p> <p>Setting this option groups the solids into logical entities.</p>
<i>dont_group_solids</i>	Some systems will group solids by default so this option allows that setting to be disabled.
<i>invisible <on/off></i>	Wireframe entities that are marked as invisible are by default NOT processed. This option allows them to be processed.
<i>no_nx_camera_fixup</i>	By default extra checks are made to prevent views with clipped geometry. This flag disables these checks.
<i>pmi_assoc_limit <off/on></i>	<p>This option is used to limit the number of PMI to Geometry associations that exist for any single PMI node. The default value being 500.</p> <p>It has been found that in rare cases many 1000's of associations exist and this has a significant effect on the translation time. If the limit is exceeded the log file reports the PMI entities names and reports an error, allowing the user to modify the limit, or review the PMI's validity.</p>
<i>set_perm <text option></i>	<p>Set the permissions for the PDF file, the options being "PRINT" or "LOCK", if no options are set then the create PDF file is fully open, the "PRINT" setting allows the file ONLY to be printed, the "LOCK" setting ensure the document cannot be modified.</p> <p>(Be aware that with Adobe Writer it is possible to override any permission setting).</p>
<i>set_perm_mask <int value></i>	<p>This allows the full control of all the permission settings when creating a PDF file, the in values need to be logically ORed together so 0x2 and 0x1 become 3. values are 0xHex (decimal)</p> <p>0x01 (1) - DocumentPermOpen The user can open and decrypt the document.</p> <p>0x02 (2) - DocumentPermSecure The user can change the document's security settings.</p> <p>0x04 (4) - DocumentPermPrint The user can print the document. Page Setup access is unaffected by this permission, since that affects Acrobat's preferences - not the document's. In the Document Security dialog, this corresponds to the Printing entry.</p> <p>0x08 (8) - DocumentPermEdit The user can edit the document more than adding or modifying text notes (see also</p>

DocumentPermEditNotes). In the Document Security dialog, this corresponds to the Changing the Document entry.

0x10 (16) - **DocumentPermCopy** The user can copy information from the document to the clipboard. In the document restrictions, this corresponds to the Content Copying or Extraction entry.

0x20 (32) - **DocumentPermEditNotes** The user can add, modify, and delete text notes (see also DocumentPermEdit). In the document restrictions, this corresponds to the Authoring Comments and Form Fields entry.

0x40 (64) - **DocumentPermSaveAs** The user can perform a Save As.... If both DocumentPermEdit and DocumentPermEditNotes are disallowed, Save will be disabled but Save As... will be enabled. The Save As... menu item is not necessarily disabled even if the user is not permitted to perform a Save As...

0x100 (256) - **DocumentPermFillandSign** Overrides other DocumentPerm bits. It allows the user to fill in or sign existing form or signature fields.

0x200 (512) - **DocumentPermAccessible** Overrides DocumentPermCopy to enable the Accessibility API. If a document is saved in Rev2 format (Acrobat 4.0 compatible), only the DocumentPermCopy bit is checked to determine the Accessibility API state.

0x400 (1024) - **DocumentPermDocAssembly** Overrides various DocumentPermEdit bits and allows the following operations: page insert/delete/rotate and create bookmark and thumbnail.

0x800 (2048) - **DocumentPermHighPrint** This bit is a supplement to DocumentPermPrint. If it is clear (disabled) only low quality printing (Print As Image) is allowed. On UNIX platforms where Print As Image doesn't exist, printing is disabled.

0x8000 (32768) - **DocumentPermOwner** The user is permitted to perform all operations, regardless of the permissions specified by the document. Unless this permission is set, the document's permissions will be reset to those in the document after a full save.

0x10000 (65536) - **DocumentPermFormSubmit** This should be set if the user can submit forms outside of the browser. This bit is a supplement to DocumentPermFillandSign.

	<p>0x20000 (131072) - DocumentPermFormSpawnTempl This should be set if the user can spawn template pages. This bit will allow page template spawning even if DocumentPermEdit and DocumentPermEditNotes are clear.</p> <p>0xFFFFFFFF - All permissions.</p>
<i>expand_part</i>	<p>This option creates a pseudo assembly structure below a part, such that each solid is modelled by a separate node. The default is to combine all solids that belong to the same part.</p> <p>Using this option can be useful when control over part with multiple solids is required, e.g. view/show separate solids, however it should be noted that this option may compromise other functionality, such as PMI association.</p>
<i>zoom_views_x <value></i>	<p>This option will magnify the view by the value provided, this is defaulted to 2.0 for all CAD systems.</p> <p>Values < 1.0 zoom out and values > 1.0 zoom in.</p> <p>The purpose of this option is to expose an adjustment factor that a given CAD system might need to best fit the VIEWS in PDF, this may be affected by the aspect ratio of the page size/template used in PDF write.</p> <p>Every effort has been made to set a good value by default.</p>
<i>use_part_names <on/off></i>	<p>When 'on' the 3DGeom node names are replaced by the TAG name from the detail (part name). Default is off.</p>
<i>pmi_flat_to_screen <on/all/off></i>	<p>This option enables the processing of flat to screen PMI data, the default is off. Please note fonts are not currently supported</p> <p>'on' allows for FLAT TO TEXT types to be processed</p> <p>'all' allows all FLAT TO SCREEN types to be processed, however only the text and NOT the frames are processed</p>
<i>attach_files_in_dir <dir></i>	<p>Attach ALL file found in specified directory</p>
<i>add_meta_data <default or <file>></i>	<p>Option to append the attributes in PDF with useful data, like part count, which can be consumed by the templates.</p> <p>default - just add part count</p> <p><file> - add the part count and process the file, such that 3 lines are processed</p>

	<p><code>part_name</code> // matches the detail (part name)</p> <p><code>attr_name</code> // name of attribute to be added</p> <p><code>attr_value</code> // value of the attribute to be added</p>
<i>move_subassy_pmi</i> <on/off/all>	Move the sub assy PMI to top level. "all" will reposition all PMI into global space which can be used for true assemblies
<i>check_facets</i>	Processing by default is optimised for facet only data. If some data is incorrectly published this option can be used to check the facet quality.
<i>expand_parts</i>	Expand the structure for a node per point using the tag name
<i>image_dir</i> <directory>	Import images into a template from a directory.

Publish 3D Interactive

Publish 3D Interactive allows an active NX Part or Assembly to be published directly into 3D PDF, directly from the NX application.

In order to publish from within NX, the NX application must be started from within a Theorem environment, so that the appropriate NX menus are loaded.

NX can be started from a shortcut, if requested at installation time. Alternatively, it can be started via the script provided in the Publish 3D installation at:

```
<installation_directory>\bin\RunNX[version].cmd
```

(where [version] should be substituted for the version of NX that you have installed – e.g., 2212 2306 2312):

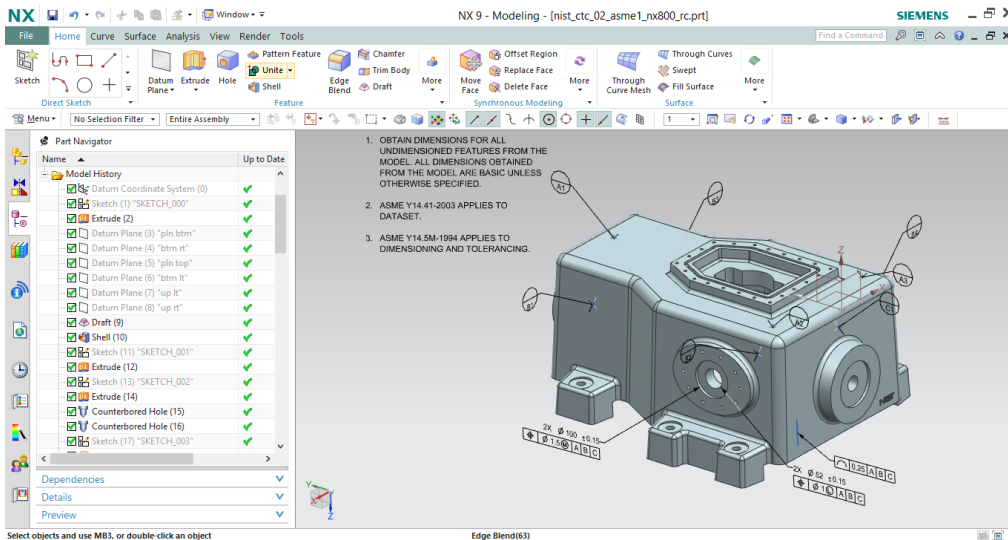

Once NX has been started and a model loaded, the active Part or Assembly can be exported by selecting the File->Export->Theorem Publish 3D Interactive menu:

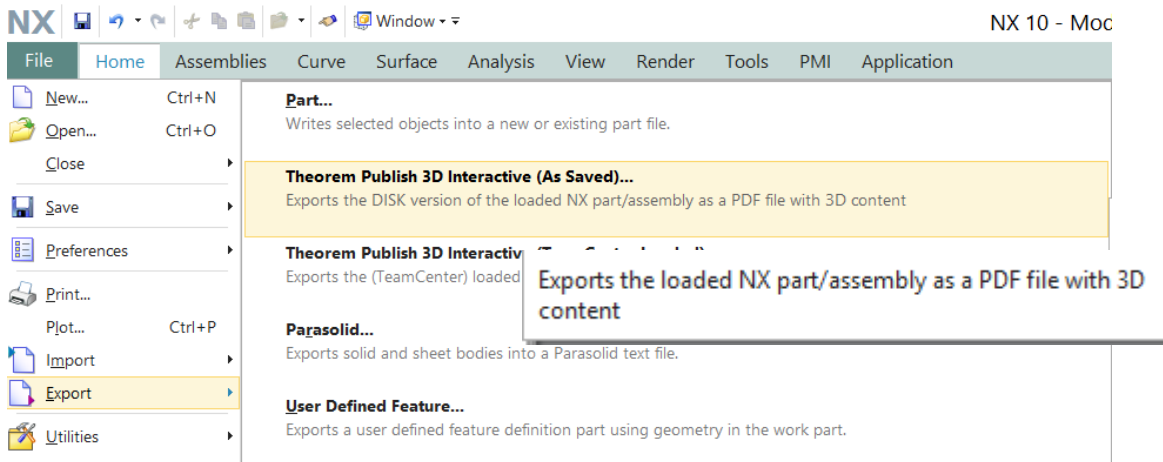

This will present the user with 2 options. If the user is using geometry loaded from the file system, then they should select (As Saved). If the models have been loaded from a TeamCenter environment then (TeamCenter Loaded) must be selected.

Having selected to export to 3D PDF the following menu will be presented to the user:

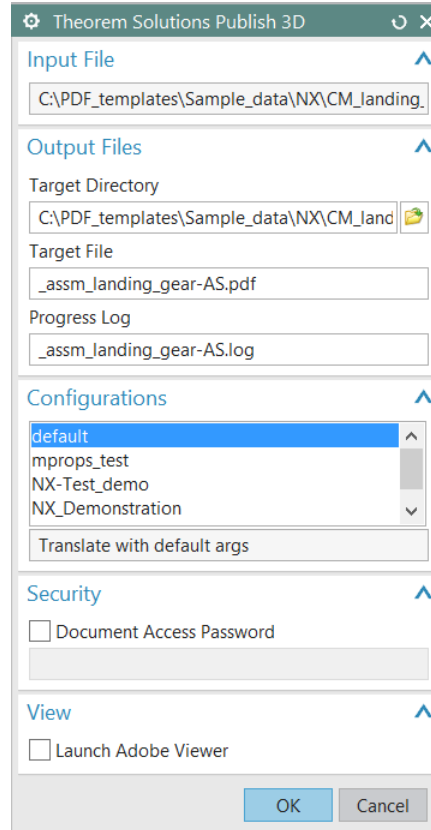

The Publish 3D Interactive interface allows the user to specify:

- A target output directory
- A target file name
- A target log file (Progress File)
- A predefined configuration files, used to set translation options and populate a predefined template

If you would like more information regarding our template design services please contact sales@theorem.com quoting “3D PDF Template Design”.

- A password for the document – if required
- The capability to launch the PDF on completion

On selecting ‘OK’ a command window will be launched to display the translation process. On completion a dialog will be displayed to inform the user of the translation success/failure:

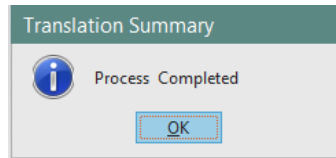

Setting your own NX Custom Dirs file

If you use your own custom_dirs.dat file with your NX installation and want to integrate Theorem menus you will need to complete the following actions:

Run “Configure.cmd” found in your Theorem software \ bin directory.

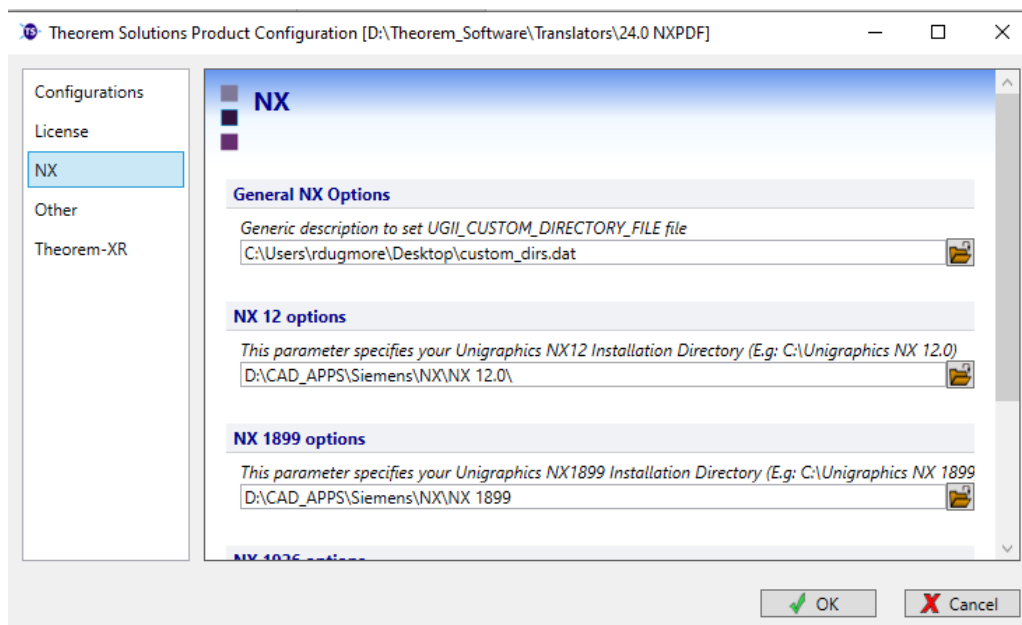

In the “General NX Options” section, select the custom_dirs.dat file that you wish to use with Theorem software.

You will then need to open your custom_dirs.dat file in a text editor and add in the following line:

```
{TS_INST}/ugmenus/v${NX_COMPATIBLE_BASE_RELEASE_VERSION}/ug_customisations
```

Once complete and you launch NX from your launcher, Theorem menus will be present to use.

Options for Processing FTA Data with Filled Text Configuration Manager

The configurations listed under the Theorem Options panel are managed using the Configuration Manager from the Unified Interface for Publish 3D *On Demand* users (See 'Configuration Manager' on Page 12).

For Publish 3D Interactive only users, the configurations are managed using a standalone Configuration Manager. The configuration manager is launched by running the ConfigurationManager.cmd file from the \bin directory of your Theorem installation. The Configuration Manager (displayed below) is used to create configurations that can define things such as which options are used to publish files to 3DPDF and what template is used. These can then be saved and selected as part of your publishing process.

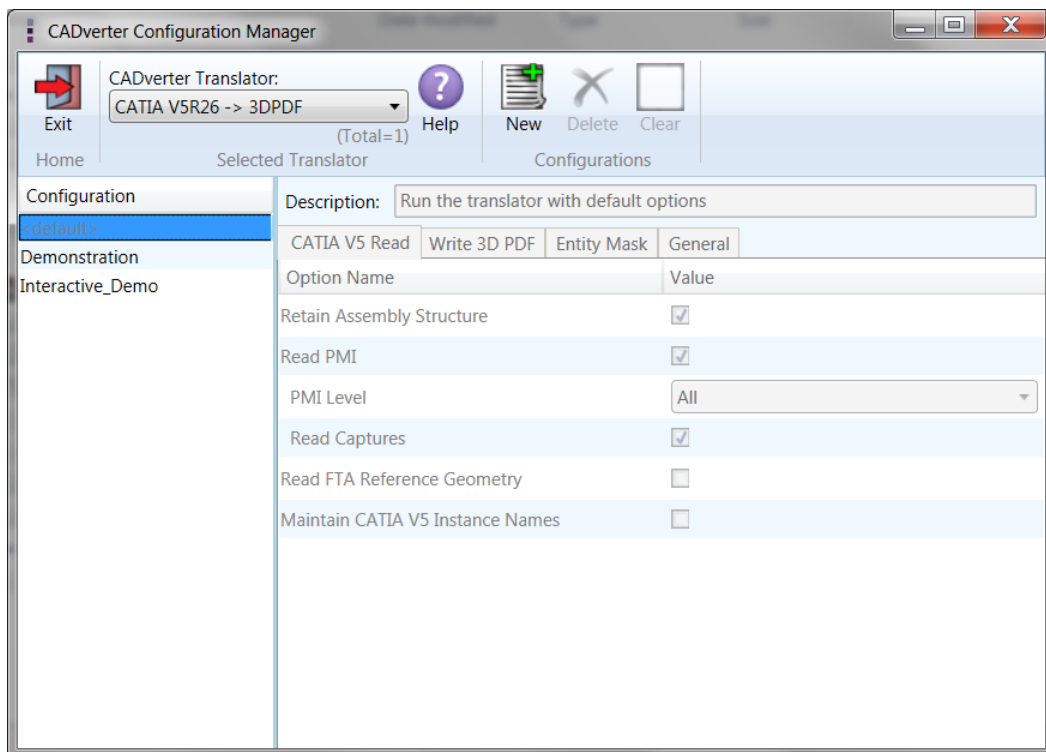

Security Changes to Adobe Reader

Adobe have implemented new security options to disable the autoplay of 3D content in PDF files. The following banner will be displayed upon opening a PDF file that contains 3D content:

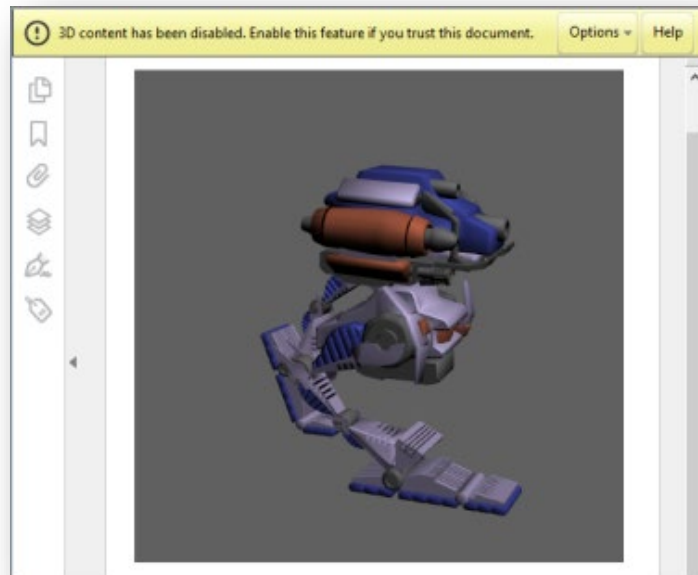

To enable 3D content in the current document:

Click the Options button and then select an appropriate option:

- Trust this document one time only
- Trust this document always

To enable 3D content permanently in ALL documents:

- Go to Edit > Preferences > 3D & Multimedia and then select the Enable playing 3D content checkbox

character outline would be reoriented and the polygon fill would remain in its original location making the output unreadable.



UK, Europe and Asia Pacific Regions

 THEOREM HOUSE
MARSTON PARK
BONEHILL RD
TAMWORTH
B78 3HU
UNITED KINGDOM

 sales.theorem@techsoft3d.com

 +44 (0) 1827 305 350

USA and the America

 THEOREM SOLUTIONS INC
100 WEST BIG BEAVER
TROY
MICHIGAN
48084
USA

 sales-usa.theorem@techsoft3d.com

 +(513) 576 1100

 THEOREM.COM